

multitek

DIGITAL PANEL METERS



THE PRODUCTS

The digital panel meter range, known as the M300 series is primarily designed for use in the power industry, but offers a wide range of both AC and DC input parameters. The applications are limitless.

Essentially there are 3 main product types :-

AC Volts, Amps, Millamps.

DC Volts, Amps, Millamps, Millivolts.

Frequency.

With the combination of a mA input the M300-AD1 and the M100 series Power Transducer, parameters such as kW, kVAR etc. can be measured and displayed.

Customer adjustment of both "ZERO" and "SPAN" is permissible via potentiometers, accessible from the rear of the product.

The meters are 3½ digit with a digit size of 14.2mm (0.56") high, 7 segment matched LEDs allowing viewing from a wide range of angles and distances.

METER REAR VIEW

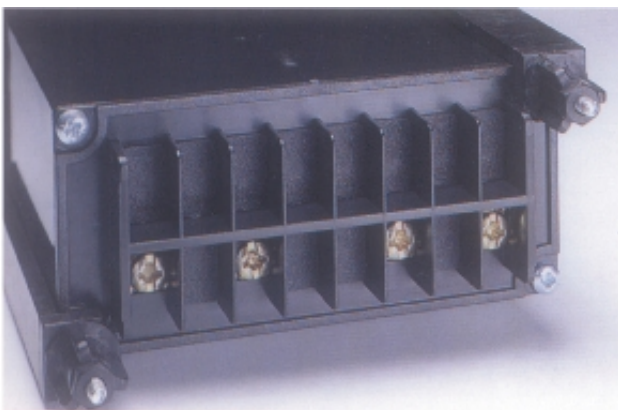

The 96 x 48 mm case is designed for fast and simple installation, using side brackets for panel mounting. The M3.5 mm terminals allow the use of traditional termination and no extra terminal kits or soldering to PCB's are required.

THEORY OF OPERATION

AC INPUTS

Both AC Voltage and Current circuits are average sensing RMS calibrated. The input signal is transformed to a low level of AC. The transformer secondary voltage is fed to a precision active rectifier, the resulting DC signal is presented to an analogue to digital converter. The A/D converter uses a dual - slope integration method of conversion. The resulting digital information is used to drive the LED display.

DC INPUTS

DC Voltage and Current inputs are fed into high stability ranging components. The ranging components reduce the input signal to a 2 Volt level. If the input is below 2 Volts an amplifier is employed to derive 2 Volts. The 2 Volt signal is then presented to the A/D converter which provides the digital information to drive the LED display.

FREQUENCY INPUTS

A frequency to Voltage F/V converter is used to convert the input signal to a DC signal. The resulting DC signal is fed in to the A/D converter and the same process as in the AC and DC circuit described above takes place.



GENERAL SPECIFICATION

INPUT	TYPE	RANGE
AC VOLTS	M300-VAD	0.....600V
DC VOLTS	M300-VD1	± 50/60/75/100/150mV
DC VOLTS	M300-VD2	± 50mV1999mV
DC VOLTS	M300-VD3	± 2V.....199.9V
DC VOLTS	M300-VD4	± 200V....600V
AC AMPS	M300-AAD	1 or 5 AC (0.2 TO 10A)
DC AMPS	M300-AD1	± 1 / 5 / 10 / 20mA
DC AMPS	M300-AD2	± 100uA.....199.9uA
DC AMPS	M300-AD3	± 20mA.....10A
DC AMPS	M300-AD4	4/20mA
FREQUENCY	M300-HZD	35Hz.....199.9Hz

INSULATION

Test Voltage 4kV RMS 50Hz 1 min

AUXILIARY

AC Voltage 115 or 230 Volts (± 25%)
45 to 65 Hz. Burden < 2VA

DC Voltage 24 / 48 / 110 Volts (± 20%)
Galvanic isolation. Burden < 3W

DISPLAY

Digits 1999 Full scale
Size 14.2mm (0.56") 7 segment red
Decimal point Internally selectable
Overrange indication Display "1" or "-1"
Update response time < 1 second
Polarity Automatic with (-) indicating negative inputs

PERFORMANCE

IMPEDANCE :-

M300-VAD	10k Ohm/V
M300-VD1/2	>100k Ohm/V
M300-VD3/4	10k Ohm/V

BURDEN

M300-AAD	< 2VA
M300-AD1/2/3/4	20mV

OVERLOAD

Current	4 x continuous 25 x 1 second
---------	---------------------------------

Voltage	1.5 x continuous 4 x 1 second
---------	----------------------------------

Accuracy	± 0.05% of reading ± 1 digit
Resolution	0.05%
Linearity	± 1 digit roll over error ± 2 digits
Conversion	Dual slope integration
CMR	AC 50dB 50 to 60 Hz DC 25 1k Ohm source unbalanced.

Normal mode rejection 25dB 50 to 60Hz

ENCLOSURE

Standard DIN case	96 x 48 x 94 mm
Panel mount	Via retaining side brackets and screws
Panel cutout	92 + 0.8mm x 45 + 0.8mm
Material	Black Polycarbonate complying with UL 94 VO
Terminals	Screw terminal for 2 x 0.5-3.5mm
Enclosure code	IP54 NEMA 12
Weight	0.4kg

GENERAL & SAFETY INSTRUCTIONS

All units built and tested for safety, accuracy, quality and reliability. Units are delivered fully calibrated, however adjustments to "ZERO" and "SPAN" can be made by removing the appropriate covers on the rear of the instrument. These products must be installed by a qualified engineer. VOLTAGE dangerous to human life may be present at some of the terminals of this unit. Exercise extreme caution during installation.

ENVIRONMENTAL

Working Temperature	0 to +60 deg C
Function Temperature	- 25 to +70 deg C
Storage Temperature	-55 to +85 deg C
Temperature Coefficient	0.01% per deg C
Relative Humidity	0-95% non condensing
Warm up time	1 min.
Shock	30G in 3 planes

CASE DIMENSIONS

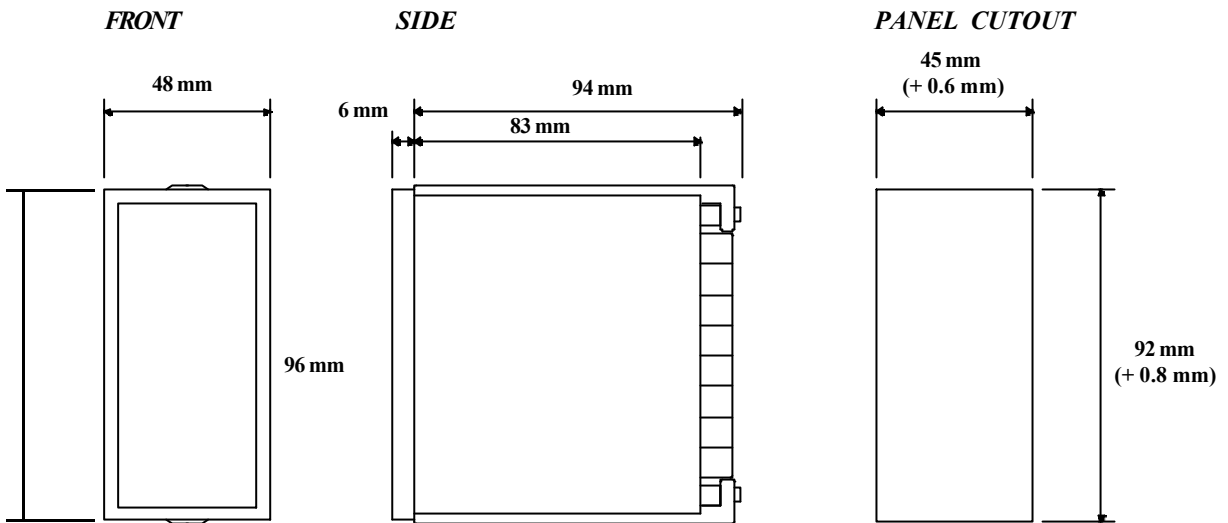

WIRING DIAGRAMS

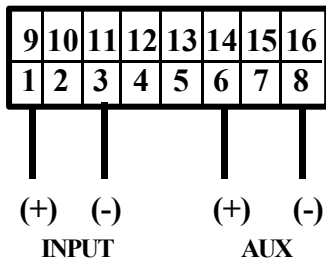

- a) All inputs (AC or DC) are connected via terminals 1 & 3
- b) All Auxiliary supplies (AC or DC) are connected via terminals 6 & 8.
- c) Access to the "ZERO" & "SPAN" adjustment. Remove terminal blanks in position 9 & 10. Zero = 10 SPAN = 9
- d) Optional external selectable decimal point. 16 = common 15 = 1.999 14 = 19.99 13 = 199.9 Link 16 as required.

multitek[®]